

The ultimate in  
pneumatic performance



**LET'S GET STARTED...**

Thank you for your purchase of UFO Aeration. UFO Aeration is recommended for hopper bottom bins that are less than 30' in diameter and have a height of less than 30' from the discharge chute of the hopper cone to the top of the bin sidewall. The UFO can accommodate loading or unloading augers of up to 10" in diameter. It is for use in grain only. Do not use it with fertilizer. Do not use it with a heater.

Figure 1A: 4-Stage UFO

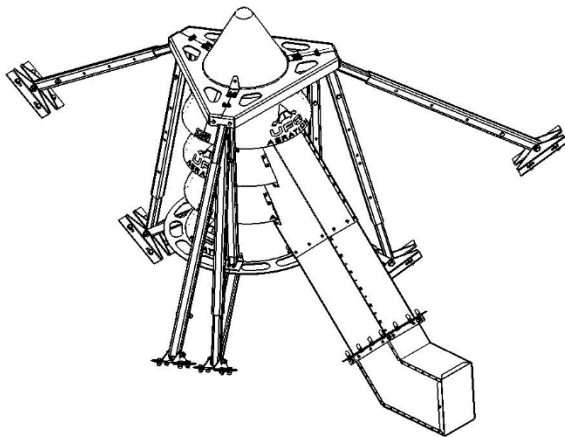


Figure 1B: 6-Stage UFO

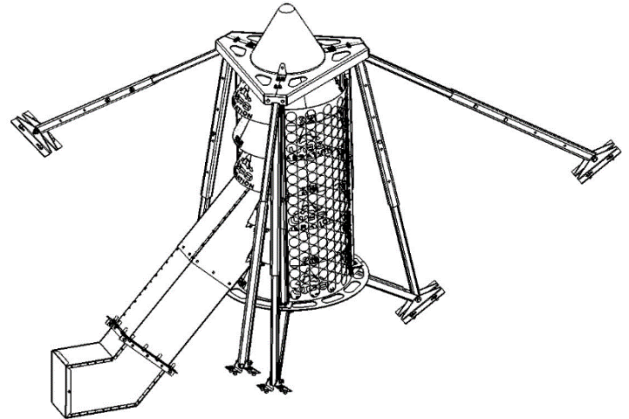
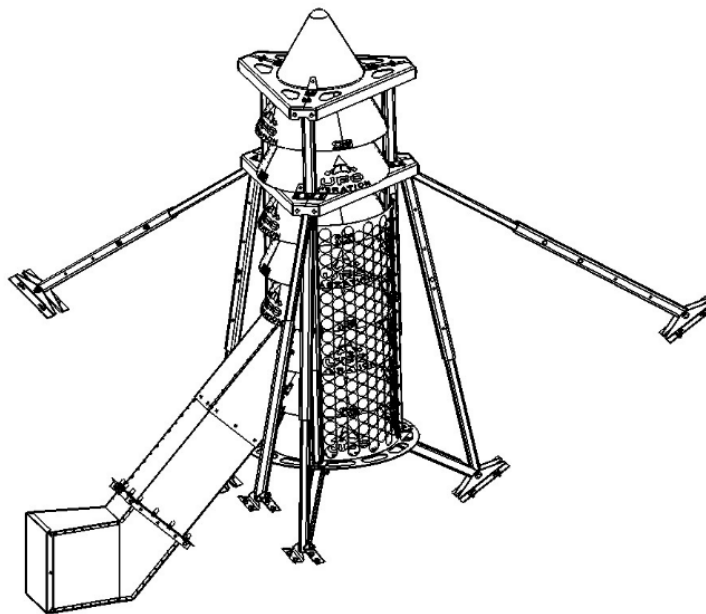


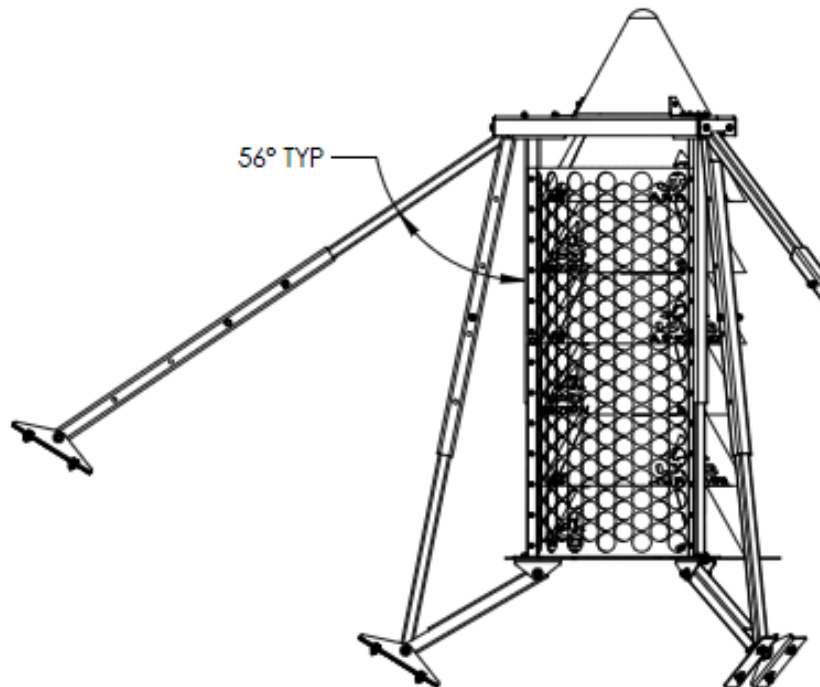
Figure 1C: 8-stage UFO



---

## IMPORTANT TO KNOW BEFORE INSTALLATION

1. The angle between the outboard legs and the vertical uprights shall not exceed  $56^\circ$  when fully installed and secured (please refer to the picture below). This will ensure optimal side-load support.
2. The telescoping outboard legs shall not be extended outward past the provided predrilled holes. This will preserve the maximum design loading capability. If the conic floor angle does not suit the existing position of the predrilled holes, drilling new holes in the outer legs is allowed as long as their location does not extend past the existing holes.



## **Disclaimer**













This document and all other collateral documents are subject to change at the sole discretion of S3 Air Systems. Illustrations and artwork contained within this manual may differ from those received.










## **SAFETY**

UFO Aeration is easy to install but does require that you know how to safely operate tools like a torch or cutting wheel. There are a few things to watch out for:













1. Wear appropriate personal protective equipment such as safety glasses, steel toed boots, and safety gloves.
2. Make sure that you have adequate light to work.
3. Make sure that if you are changing up the number of stages or disassembling your UFO Aeration to use in a different bin, that the aeration fan is disconnected and the bin is empty.
4. If your bin is already standing, you are going to have to get in the bin to install your UFO Aeration. Make sure you open the bin lid and prop open the door to ensure you have appropriate ventilation.
5. If you are entering the bin, make sure that someone knows where you are and when you are expected home. The safest way to approach this installation is to have someone assist you.

## 4-STAGE UFO PARTS LIST










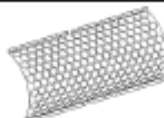
Part Identifier	Description 1	Description 2	Quantity	UOM	Thumbnail
31-117379-23	BASE LOWER SUPPORT PAINT	GRAY	3	EA	
31-117560-23	CROWN PLATE PAINT	GRAY	3	EA	
31-117536-23	UFO BASE SUPPORT	GRAY	1	EA	
31-117404-1	LOWER OUTBOARD PAINT	BLACK	3	EA	
31-117392-23	LOWER INBOARD PAINT (46-1/2" WITH WASHERS)	GRAY	3	EA	
31-117377-23	LEG BASE PAINT	GRAY	3	EA	
31-117537-23	UFO COLUMN BASE 36"	GRAY	3	EA	
31-117538-1	UFO COLUMN TOP 36" (WITH BOLTS INSTALLED)	BLACK	3	EA	
31-117542-23	UPPER OUTBOARD 1-1/2" (WITH CAP)	GRAY	3	EA	
31-117543-1	UPPER INBOARD (NOTCHED AND COVERED AT END WITH HOLE)	BLACK	3	EA	
3510-00-0001	STAGE HALF UFO	POLYMER	8	EA	
31-117372	DUCT UPPER ASSY 9X14	GALVANIZED	1	EA	

Part Identifier	Description 1	Description 2	Quantity	UOM	Thumbnail
31-117373	DUCT LOWER ASSY 9X14	GALVANIZED	1	EA	
31-117374	DUCT ELBOW ASSY 9X14	GALVANIZED	1	EA	
31-117375-23	FLANGE VERTICAL 14" PAINT	GRAY	2	EA	
31-117376-23	FLANGE HORIZONTAL 9" PAINT	GRAY	2	EA	
31-117381-23	CLAMP TAB PAINT	GRAY	3	EA	
2430-01-3091	UFO LEG ANGLE JIG	ALUMINUM OR PLASTIC	1	EA	
31-117382-23	FOOT PAINT	GRAY	3	EA	
31-117576-23	FOOT DOUBLE PAINT UFO	GRAY	12	EA	
31-117546	UFO NOSE CONE	POLYMER, FOAM FILLED	1	EA	
31-117388	BOLT KIT - VERTICAL UNIVERSAL	PURCHASED KIT	1	EA	
3890-00-0027	NDA-X 1/8"X3/8"X10FT	NEOPRENE ROLL	1	EA	
31-117390-V3	UFO-V3 AERATION MANUAL	BOOKLET	1	EA	















## 6-STAGE UFO PARTS LIST











Part Identifier	Description 1	Description 2	Quantity	UOM	Thumbnail
31-117379-23	BASE LOWER SUPPORT PAINT	GRAY	3	EA	
31-117560-23	CROWN PLATE PAINT UFO	GRAY	3	EA	
31-117536-23	UFO BASE SUPPORT	GRAY	1	EA	
31-117404-1	LOWER OUTBOARD PAINT	BLACK	3	EA	
31-117392-23	LOWER INBOARD PAINT (46-1/2" WITH WASHERS)	GRAY	3	EA	
31-117377-23	LEG BASE PAINT	GRAY	3	EA	
31-117537-23	UFO COLUMN BASE 36"	GRAY	3	EA	
31-117538-1	UFO COLUMN TOP 36" (WITH BOLTS INSTALLED)	BLACK	3	EA	
31-117542-23	UPPER OUTBOARD 1-1/2" (WITH CAP)	GRAY	3	EA	
31-117543-1	UPPER INBOARD (NOTCHED AND COVERED AT END WITH HOLE)	BLACK	3	EA	
3510-00-0001	STAGE HALF UFO	POLYMER	12	EA	
31-117372	DUCT UPPER ASSY 9X14	GALVANIZED	1	EA	



Part Identifier	Description 1	Description 2	Quantity	UOM	Thumbnail
31-117373	DUCT LOWER ASSY 9X14	GALVANIZED	1	EA	
31-117374	DUCT ELBOW ASSY 9X14	GALVANIZED	1	EA	
31-117375-23	FLANGE VERTICAL 14" PAINT	GRAY	2	EA	
31-117376-23	FLANGE HORIZONTAL 9" PAINT	GRAY	2	EA	
31-117381-23	CLAMP TAB PAINT	GRAY	3	EA	
2430-01-3091	UFO LEG ANGLE JIG	ALUMINUM OR PLASTIC	1	EA	
31-117382-23	FOOT PAINT	GRAY	3	EA	
31-117576-23	FOOT DOUBLE PAINT UFO	GRAY	12	EA	
31-117546	UFO NOSE CONE	POLYMER, FOAM FILLED	1	EA	
31-117388	BOLT KIT - VERTICAL UNIVERSAL	PURCHASED KIT FOR SCREEN ASSY	1	EA	
3890-00-0027	NDA-X 1/8"X3/8"X10FT	NEOPRENE ROLL	1	EA	
31-117390-V3	UFO-V3 AERATION MANUAL	BOOKLET	1	EA	
31-117629	UFO PERFORATED SUP ASSY		1	EA	

## 8-STAGE UFO PARTS LIST

Part Identifier	Description 1	Description 2	Quantity	UOM	Thumbnail
31-117379-23	BASE LOWER SUPPORT PAINT	GRAY	3	EA	
31-117560-23	CROWN PLATE PAINT UFO	GRAY	3	EA	
31-117569-23	CROWN PLATE MID 8 ST PAINT UFO	GRAY	3	EA	
31-117536-23	UFO BASE SUPPORT	GRAY	1	EA	
31-117404-1	LOWER OUTBOARD PAINT	BLACK	3	EA	
31-117392-23	LOWER INBOARD PAINT (46-1/2" WITH WASHERS)	GRAY	3	EA	
31-117377-23	LEG BASE PAINT	GRAY	3	EA	
31-117537-23	UFO COLUMN BASE 36"	GRAY	3	EA	
31-117538-1	UFO COLUMN TOP 36" (WITH BOLTS INSTALLED)	BLACK	3	EA	
31-117542-23	UPPER OUTBOARD 1-1/2" (WITH CAP)	GRAY	3	EA	
31-117543-1	UPPER INBOARD (NOTCHED AND COVERED AT END WITH HOLE)	BLACK	3	EA	
31-117559-1	COLUMN 8 ST PAINT UFO	BLACK	3	EA	
3510-00-0001	STAGE HALF UFO	POLYMER	16	EA	
31-117372	DUCT UPPER ASSY 9X14	GALVANIZED	1	EA	

Part Identifier	Description 1	Description 2	Quantity	UOM	Thumbnail
31-117373	DUCT LOWER ASSY 9X14	GALVANIZED	1	EA	
31-117400	DUCT ELBOW ASSY 12X17	GALVANIZED	1	EA	
31-117375-23	FLANGE VERTICAL 14" PAINT	GRAY	2	EA	
31-117376-23	FLANGE HORIZONTAL 9" PAINT	GRAY	2	EA	
31-117381-23	CLAMP TAB PAINT	GRAY	3	EA	
2430-01-3091	UFO LEG ANGLE JIG	ALUMINUM OR PLASTIC	1	EA	
31-117382-23	FOOT PAINT	GRAY	3	EA	
31-117576-23	FOOT DOUBLE PAINT UFO	GRAY	12	EA	
31-117546	UFO NOSE CONE	POLYMER, FOAM FILLED	1	EA	
31-117388	BOLT KIT - VERTICAL UNIVERSAL	PURCHASED KIT FOR SCREEN ASSY	1	EA	
3890-00-0027	NDA-X 1/8"X3/8"X10FT	NEOPRENE ROLL	1	EA	
31-117390-V3	UFO-V3 AERATION MANUAL	BOOKLET	1	EA	
31-117629	UFO PERFORATED SUP ASSY		1	EA	

## INSTALLATION

You are going to need a few tools:

1. Electric drill with 7/16" bit, 3/16" bit and a 1/2" bit
2. Ox-fuel cutting torch or hand grinder with part off wheel
3. Marker
4. Level
5. 9/16" and 3/4" open ended wrench
6. 9/16" and 3/4" ratchet sockets and ratchet
7. 5/16" and 3/8" hex driver bit
8. Duct tape
9. Fire extinguisher
10. Tape measure
11. A punch to help with pin alignment
12. Tightening specifications, listed below in Table 1

Table 1: Tightening Specifications

Bolt Diameter	Tightening Torque	
	Metal	Polymer
3/8" NC bolt and nut	40 ft-lbs	15 ft-lbs
1/2" NC bolt and nut	45 ft-lbs	Not applicable
1/4" Self-tapping screw – ducting, modules, and cone	Until screw flange contacts the metal surface, use discretion	Until screw flange contacts the polymer surface, use discretion

---

We have broken the installation into the following steps –

- **4 Stage**

1. Assemble the Lower Support Base Sub Assembly
2. Mount the Lower Support Base Sub Assembly and add the Gray Inboard Legs
3. Mount the 1<sup>st</sup> Stage and the Column Legs to the Lower Support Base Sub Assembly
4. Assemble and Mount the Remaining UFO Stages
5. Assemble the Inboard Legs
6. Install the Crown Plate
7. Install the Nose Cone
8. Install the Outboard Legs
9. Install the Ducting

- **6 Stage**

1. Assemble the Lower Support Base Sub Assembly
2. Mount the Lower Support Base Sub Assembly and add the Gray Inboard Legs
3. Mount the 1<sup>st</sup> Stage and the Column Legs to the Lower Support Base Sub Assembly
4. Assemble and Mount the Remaining UFO Stages
5. Assemble the Inboard Legs
6. Install the Crown Plate
7. Install the Nose Cone
8. Install the Outboard Legs
9. Install the Ducting
10. Install the support screen
11. (Optional) Transition Kit Step from 6 Stage V3 to 8 Stage V3

- **8 Stage**

1. Assemble the Lower Support Base Sub Assembly
2. Mount the Lower Support Base Sub Assembly and add the Gray Inboard Legs
3. Mount the 1<sup>st</sup> Stage and the Column Legs to the Lower Support Base Sub Assembly
4. Assemble and Mount the Remaining UFO Stages
5. Assemble the Inboard Legs
6. Install the Upper Ring, Assemble and Mount Two UFO Stages, Install the 3 Top Column Legs.
7. Install the Nose Cone
8. Install the Outboard Legs
9. Install the Ducting
10. Install the support screen

---

## Let's Get Started....

### 1. ASSEMBLE THE LOWER SUPPORT BASE SUB ASSEMBLY – (ALL MODELS)

You are going to need:

1 – Base Lower Support, made up of 3 identical parts that will form a full ring that is 36” in diameter

3 – Base leg, 22” long, painted gray

3 – Inboard Legs, 46 ½” long, painted gray

3 – Foot - “U” shaped

6 – Double Foot - “L” shaped

1 – Leg Angle Jig

From the Bolt Kit:

6 – 3/8” whiz bolts

6 – 3/8” whiz nuts

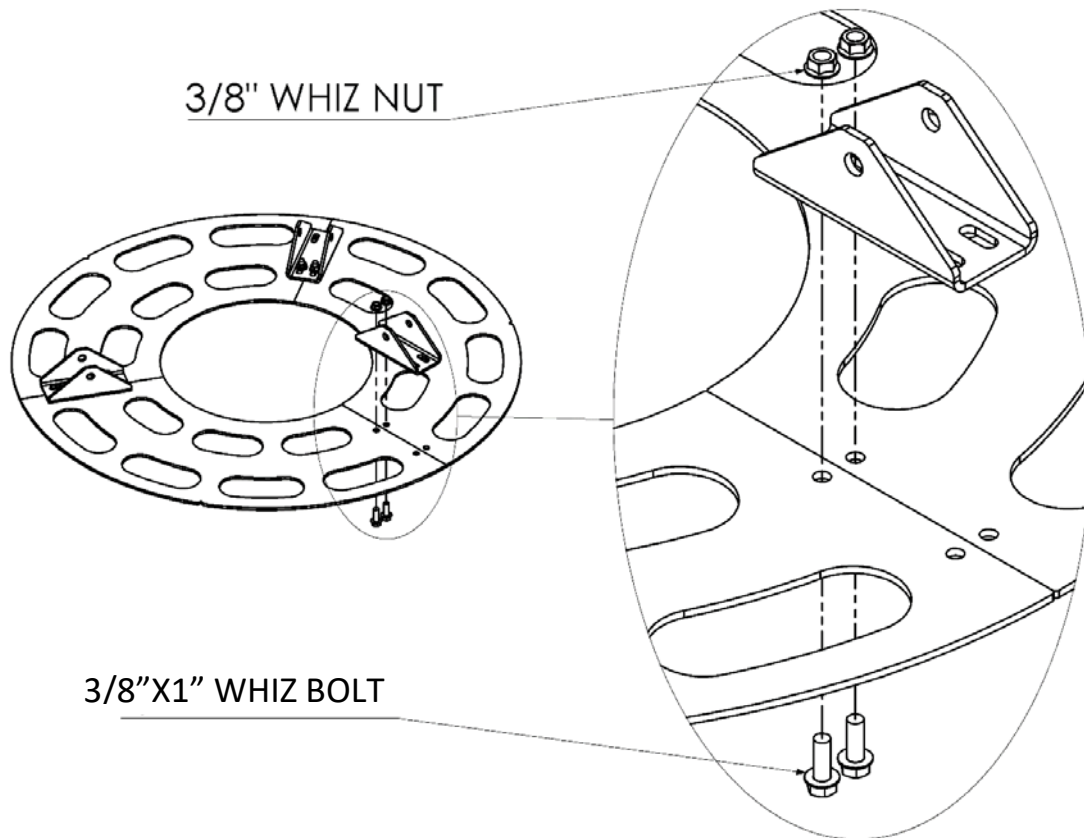
6 – 1/2” x 3 1/2” bolts (watch out, there are also 1/2” bolts that are only 3” long that you will need elsewhere)

12 – 1/2” washers

6 – 1/2” nuts

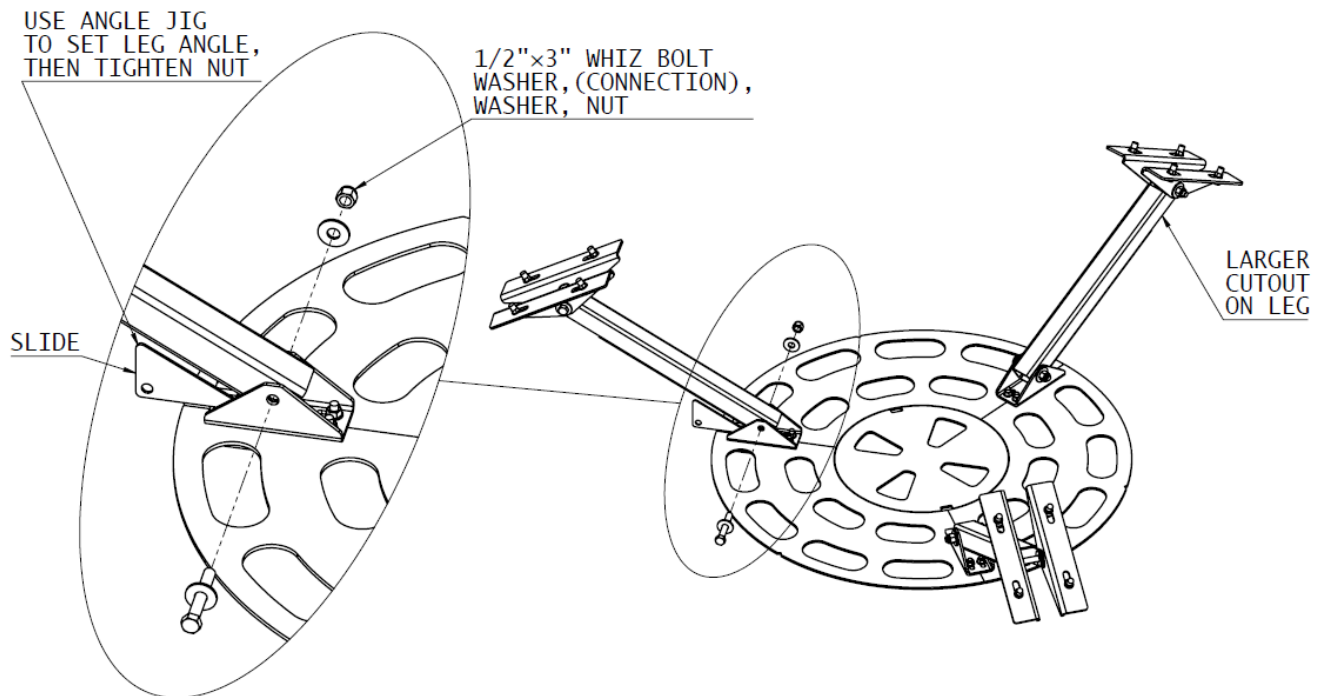
Assemble the Base Lower Support by using three Mounting Foot brackets (U-shaped). Bolt each to the joint of the adjacent base 1/3 section using two 3/8” bolts and nuts per Foot Bracket in the inner bolt positions on the lower base component, as per Figure 2. The bolts should be positioned approximately at the midpoint of the Foot Bracket's slots. Tighten all hardware to the appropriate torque.

Figure 2: Base Ring Assembly



With the Feet Double Brackets facing upward (yes, the Base Lower Support is upside down but, trust us, it's easier); bolt the un-slotted end of the Base Legs to the Feet Double Bracket, using one 1/2" bolt, two 1/2" washers, and one 1/2" nut per Foot Bracket. The slotted side of the Base Legs should be facing downwards.

Figure 3: Lower Support Base Sub Assembly



- Bolt two “L”-shaped Double Feet to the slotted end of each of the Short Legs, using one 3-1/2” x 1/2” bolt, two 1/2” washers, and one 1/2” nut per Double Foot, as per Figure 3. Thread the nuts on finger tight – they will be removed temporarily for the next step.
- Flip the Lower Support Base right side up and position it so that it finds itself directly over the center of the hopper cone hole.



---

## 2. MOUNT THE LOWER SUPPORT BASE SUB ASSEMBLY AND ADD THE GRAY INBOARD LEGS

You are going to need:

- 1 – Lower Support Base Assembly
- 1 – UFO Base Support
- 3 – Lower Inboard

Consider where you want to position the ducting that connects your aeration fan to your UFO Aeration. Rotate the Lower Support Base Sub Assembly into a position that aligns one of the V-notches, as shown in Figure 4, in the Lower Base Support with where the ducting will go.

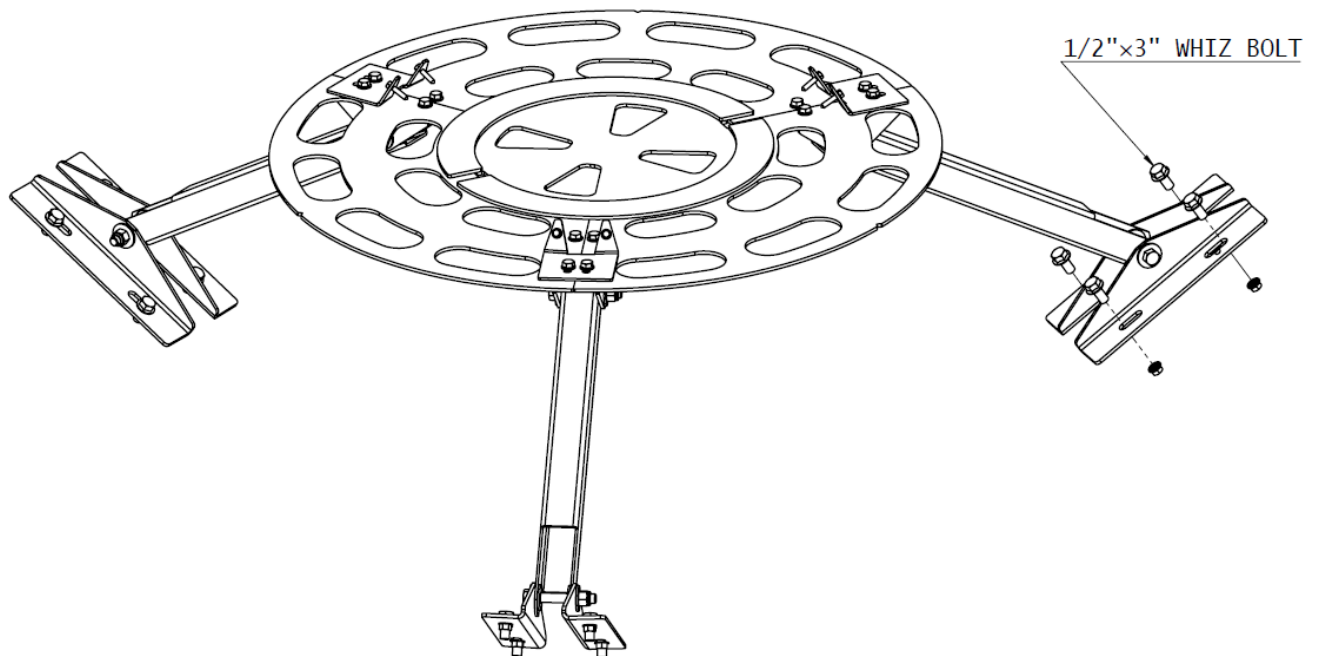
Figure 4: V-notch



- Re-check the angle of each leg. It is critical that this angle is correct for later components to line up properly. Measure from the edge of the hopper bottom opening to the bottom edge of all three feet to help ensure the UFO is positioned concentric to the opening.
- Use your level to ensure that the UFO is level horizontally and vertically.
- Position the bottom Double Feet so they rest comfortably on the hopper cone. Mark each of the Double Feet's 4 holes onto the hopper's surface using a marker.
- Move the Lower Support Base Sub Assembly out of your way.
- Using your 7/16" drill bit, drill the 12 holes in your hopper.

- Put the Lower Support Base Sub Assembly back into position. Make sure that one of the V-notches is still aligned with where you want your ducting to go.
- Bolt the bottom Double Feet (4, 6 and 8-stage UFO) to the hopper using four 3/8" bolts and nuts per Foot, as per Figure 5. The nuts will be on the outside of the bin.

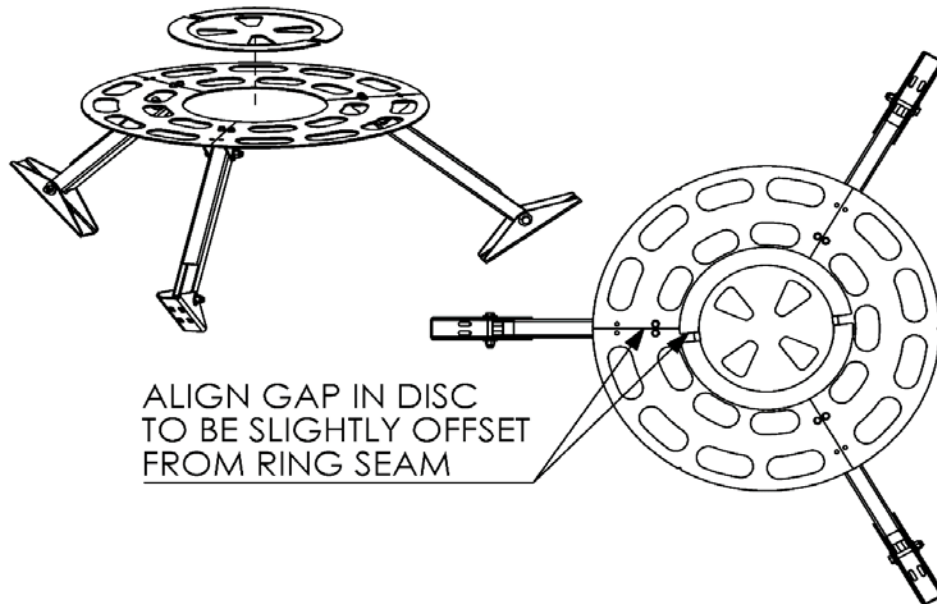
Figure 5: Lower Support Base Sub Assembly Mounting



**NOTE:** If you need it, you now have a platform you can stand on for the rest of the assembly process.

- Insert the Base Support disc so that it is nested into the hole in the Base Ring. Position it so that one side of the gap on the Base Support Disc is slightly offset from a seam on the base lower support, and the other is slightly offset from the notch on the opposite side where the ducting will be installed. See Figure 6.

Figure 6: Base Disc Installation



Check out your Gray Base Legs. One end of each long inboard leg should have a washers welded to it. Carefully remove one 1/2" nut and washer from a mounting foot. Pull the bolt almost fully out, and install the long leg (washer side at this connection) by pushing the bolt through the foot, short leg, and long leg, all the way through the other side. Use a punch to help align all the holes. Re-install the washer and nut, and this time tighten the nut to the specified torque value. Repeat for the other two legs. See Figure 7 and Figure 8.

On 4, 6 and 8-Stage UFO's there are 2 "L" shaped double feet to be installed on each leg, with the horizontal flange facing outboard.

The pictures show the installation of the "L" shaped foot.

Figure 7: Long Gray Inboard Leg Installation

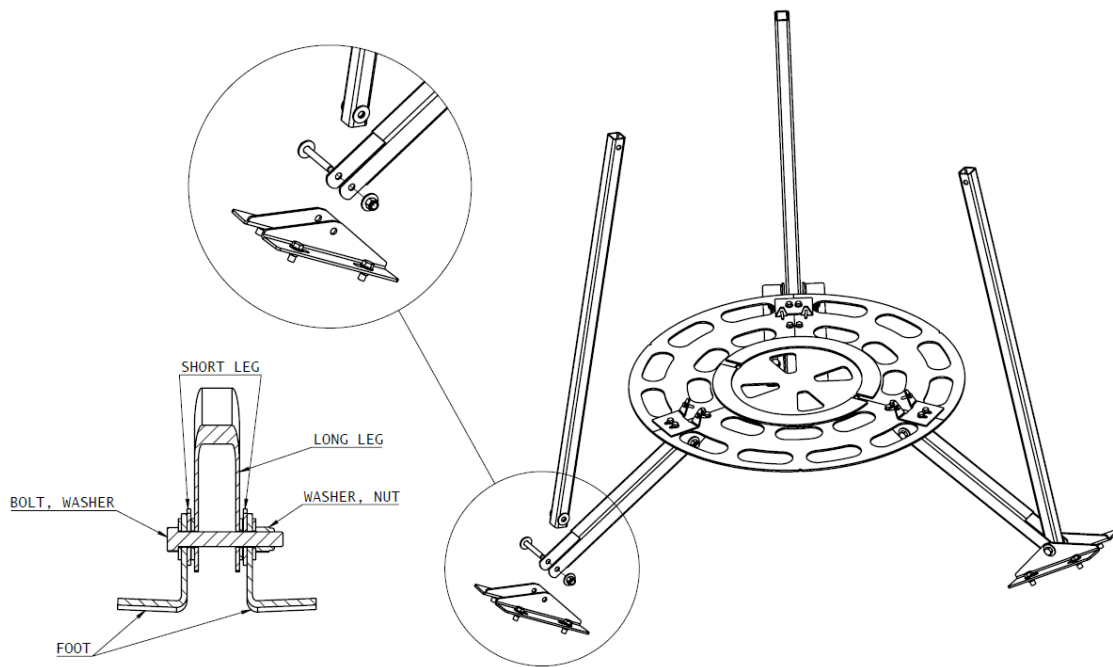


Figure 8: Close up of Legs





---

### 3. MOUNT THE 1<sup>st</sup> STAGE AND THE LOWER COLUMN GRAY LEGS TO THE LOWER SUPPORT BASE SUB ASSEMBLY (ALL MODELS)

You are going to need:

1 – Stage, made up of 2 Halves

From the Bolt Kit:

06 – Self-tapping ¼” screws

12 – 3/8”x1-1/2” whiz bolts

12 – ½” flat washers

12 – 3/8” whiz nuts

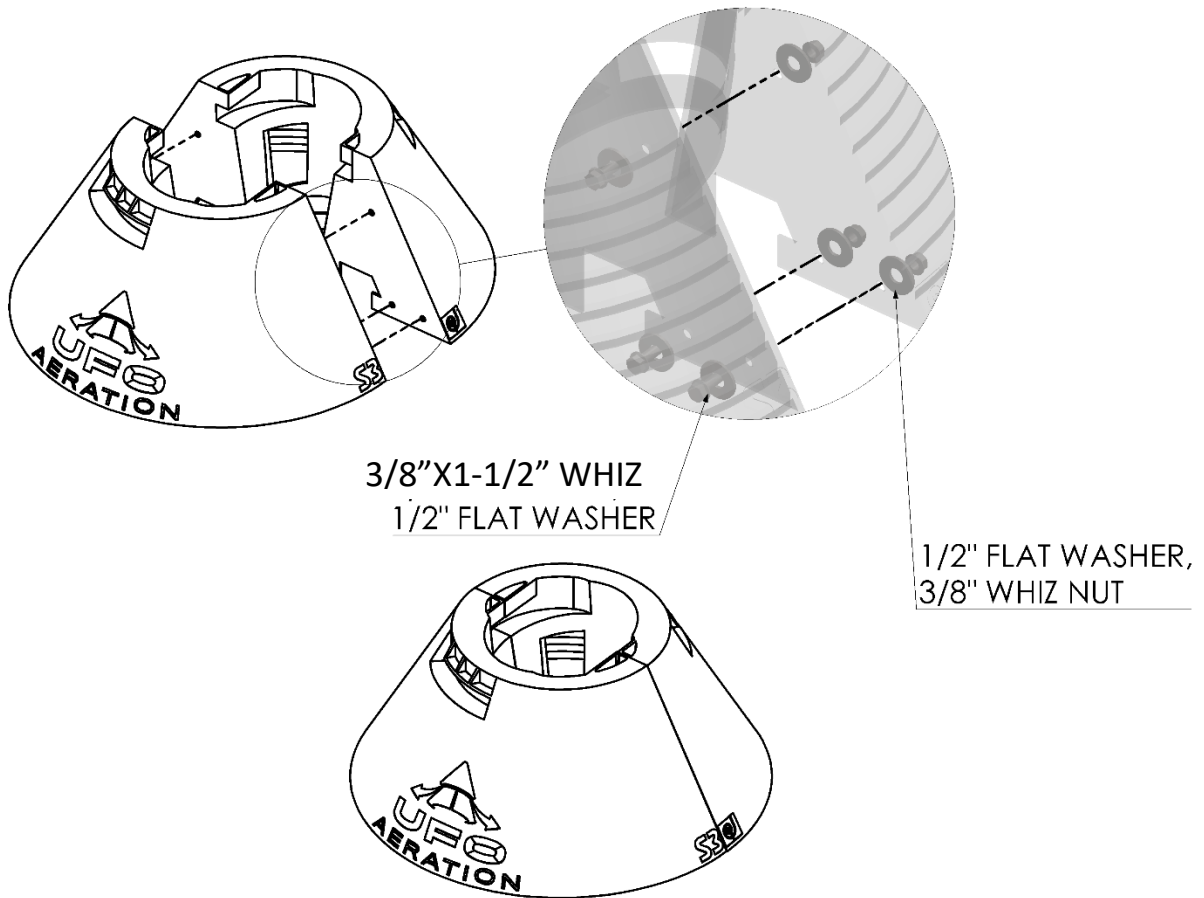
3 – Lower Column Legs, 36” long with a plate welded on the bottom, painted gray

- Using 3/8” bolts and nuts with 1/2” flat washers, bolt together the first of the Halves to form a UFO Stage, as per Figures 9 and 10. When you are done bolting the halves together, there may be a small amount of separation at the inner seams of your stage. As long as the exterior seams are tight, you are fine. The separation at the inner seam is a normal condition of the polymer and helps secure the stages when they interlock together.

Figure 9: Bolting the Halves to make a Stage

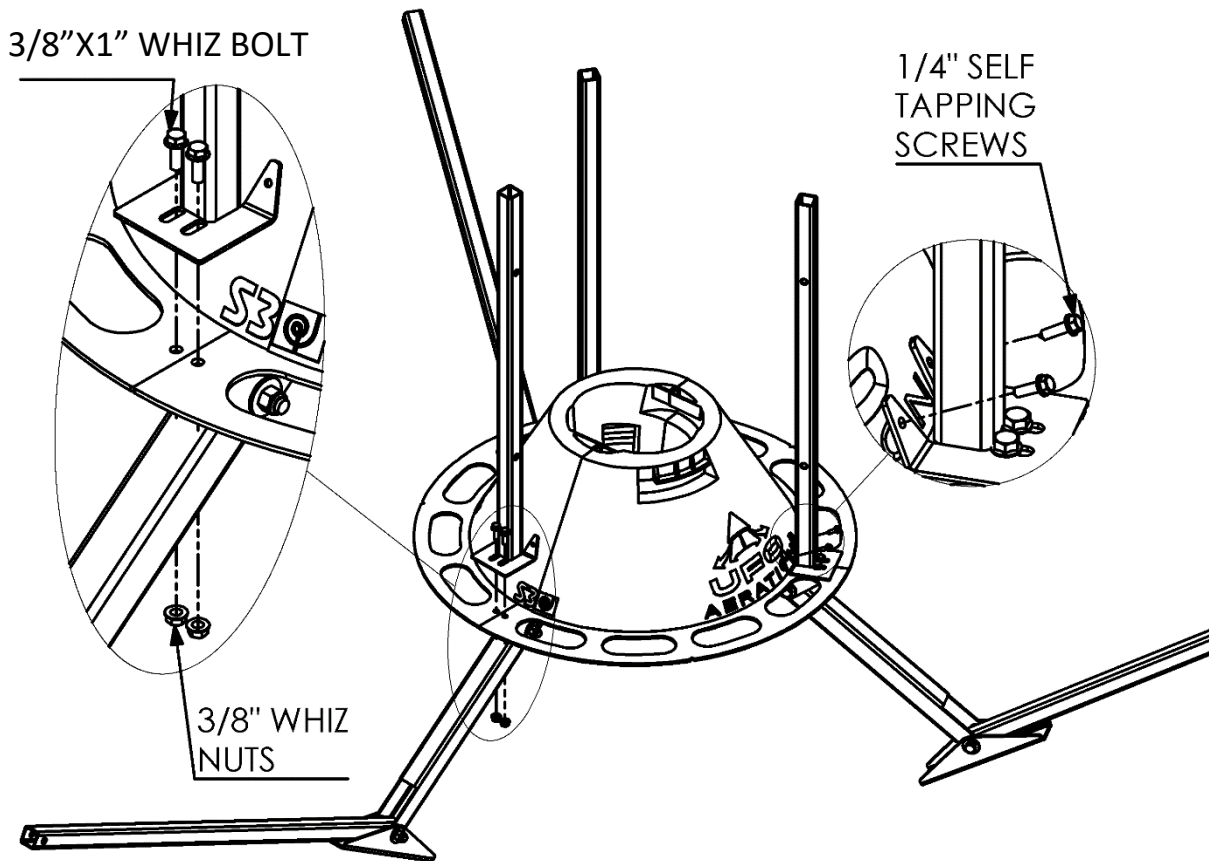


Figure 10: Bolting the Halves to make a Stage



- Position the 1st UFO Stage centrally on top of the Base Ring Sub Assembly as per Figure 11. The seam of the Stage must nest into the gap on the Base Disc. If the seam interferes with the bolts installed on the Base Ring, it is ok to rotate it and the Base Disc together so they are just slightly to one side. Ensure that the Base Disc is sitting nested into the Base Ring, and the 1st Stage is sitting nested into the Base Disc.
- Because you won't be able to later mount the ducting over a seam in the UFO Stages, it is important to rotate the 1<sup>st</sup> UFO Stage to the appropriate position.
- To figure out the appropriate position, first identify the leg that is directly opposite from the V-notch you are using to align your ducting. Rotate the 1<sup>st</sup> UFO Stage so that the angled tab on this leg is touching the "S3" logo on the stage. Ensure that the stage is still properly nested into the Base Disc, and the Base Disc into the Base Ring.

Figure 11: Installing the 1<sup>st</sup> Stage and Lower Column Gray Legs



- Place one Base Column Leg, plate down, on top of the Lower Support, with the bent side of the plate pushed tight up against the 1st Stage as per Figure 11. Align the slots with a set of open holes on the Lower Support. Place two 3/8" bolts through these slots and holes and through the "U"-shaped foot slots underneath on the opposite side. Thread the nuts on the bottom. Repeat step for the other two Base Column Legs. Tighten to appropriate torque specification.
- Fasten the six 1/4" self-tapping screws through the tabs on the legs and into the 1st Stage to hold it in place.

#### 4. ASSEMBLE AND MOUNT THE REMAINING UFO STAGES (ALL MODELS)

You are going to need:

Stages, made up of 2 Halves:

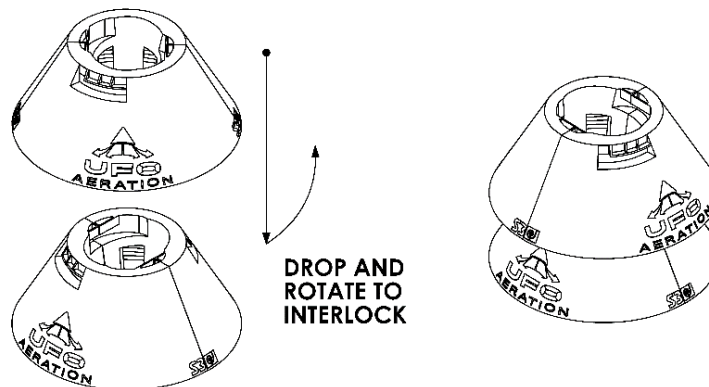
- UFO 4 Stage Kit = 6 more Halves
- UFO 6 Stage Kit = 10 more Halves
- UFO 8 Stage Kit = 14 more Halves

From the Bolt Kit:

- 6 self-tapping 1/4" screws
- 6 per UFO Stage – 3/8"x1-1/2" whiz bolts
  - UFO 4 Stage Kit = 18 more
  - UFO 6 Stage Kit = 30 more
  - UFO 8 Stage Kit = 42 more
- 6 per UFO Stage – 3/8" whiz nuts
  - UFO 4 Stage Kit = 18 more
  - UFO 6 Stage Kit = 30 more
  - UFO 8 Stage Kit = 42 more
- 12 per UFO Stage – 1/2" Flat Washers
  - UFO 4 Stage Kit = 36 more
  - UFO 6 Stage Kit = 60 more
  - UFO 8 Stage Kit = 84 more

- Assemble the remainder of the halves into stages for the kit as per Figures 9 and 10.
- Lower the 2<sup>nd</sup> UFO Stage onto the 1<sup>st</sup> UFO Stage by aligning the 2<sup>nd</sup> UFO Stage's interior tabs with the 1<sup>st</sup> UFO Stage's exterior notches and rotate the 2<sup>nd</sup> UFO Stage counter clockwise until you reach the end of the rotation stroke, as per Figure 12.

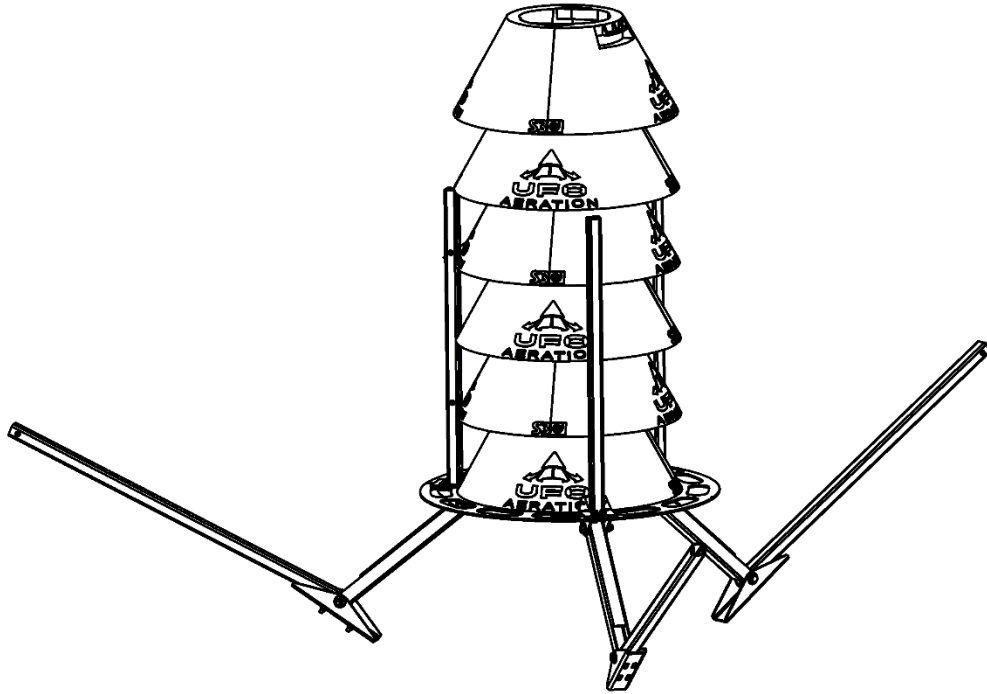
Figure 12: Interlocking the Stages





- Repeat. And repeat. And repeat until all Stages are on the unit as shown in Figure (6 Stage unit depicted).

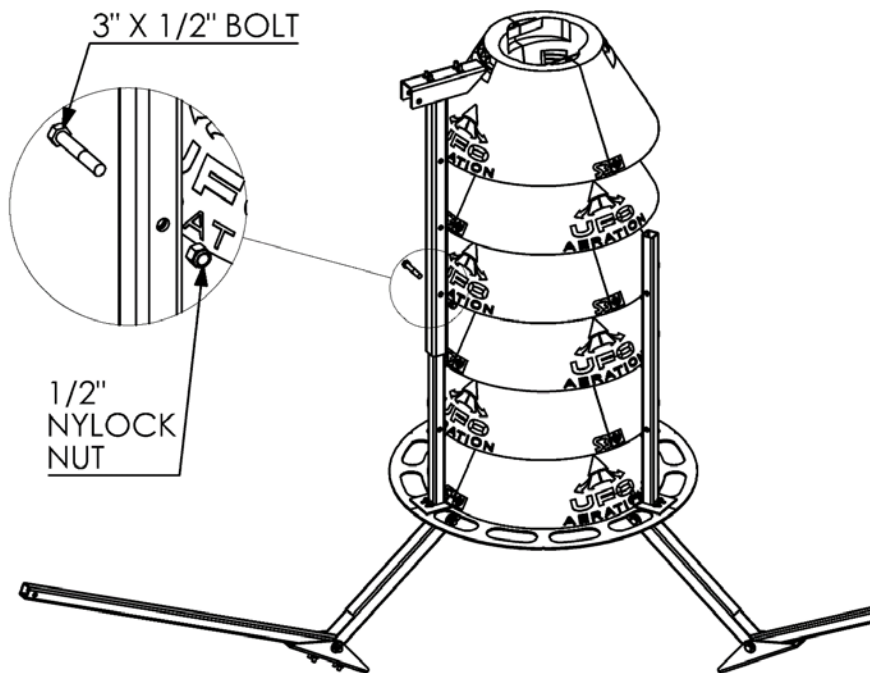
Figure 13: All Stages Installed



## 5. ASSEMBLE THE INBOARD LEGS (ALL MODELS)

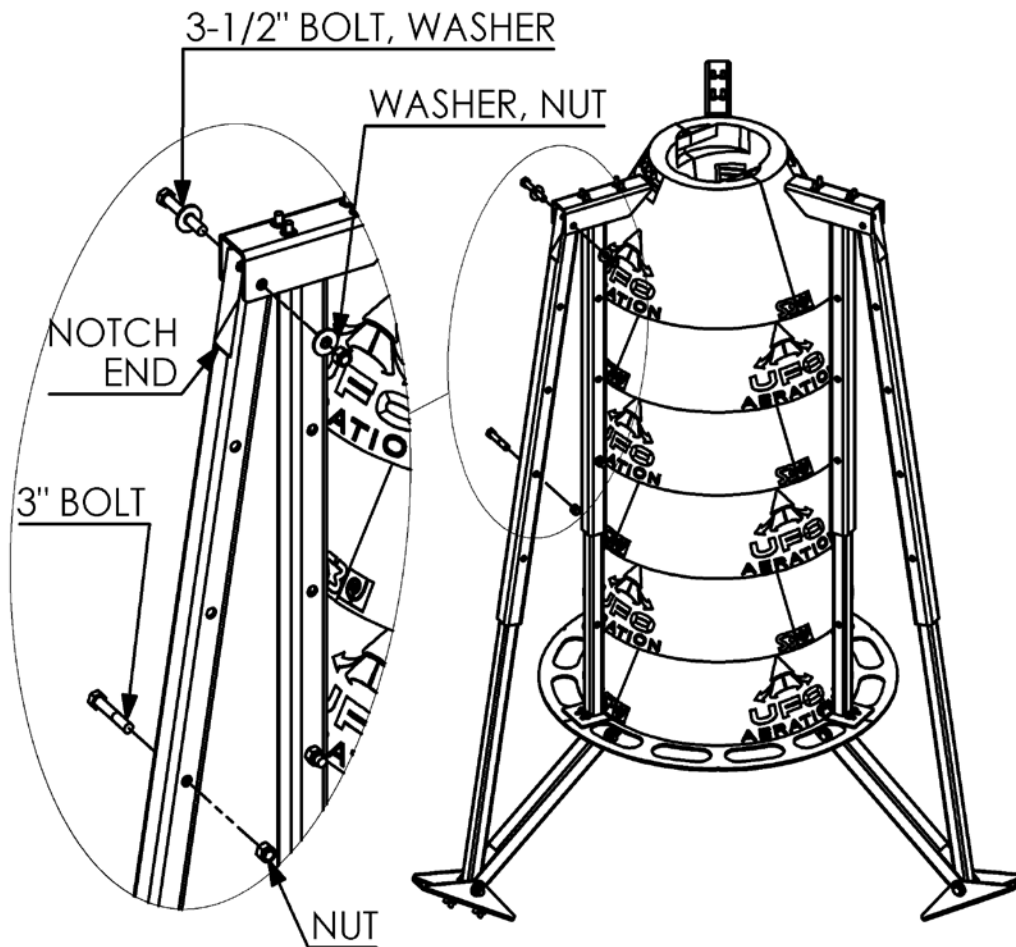
- You are going to need:
  - 3 – UFO Column Top 36" (Black Legs)
  - 3 – Upper Inboard Black (with a notch cut out on one end)
- From the Bolt Kit:
  - 3 – 1/2" x 3"bolts
  - 3 – 1/2" x 3-1/2" bolts
  - 6 – 1/2" Nylock nuts
- Take a UFO Column Top Black Leg (with the bracket welded on top) and place it over the top of one of the Base Column Gray Legs. If building a 4 stage, align the bottom hole on the Top Column Leg with the bottom hole on the Base Column Gray Leg. If building a 6 Stage or 8 Stage unit, align the bottom hole on the black leg and the 2nd hole on the gray leg. Insert the 1/2" x 3" bolt and tighten on the Nylock nut. See Figure 14. Repeat for the other two legs.

Figure 14: Installing the 36" Upper Column Black Leg



- Take a 44" Upper Inboard and slide it over the 46-1/2" Inboard Gray Leg which is in line with the leg assembled in the previous step. Pivot the gray and black legs up and attach the Inboard black leg at the top hole to the bracket at the top of the 36" black leg using a 1/2" x 3-1/2" bolt, two flat washers, and a 1/2" nylock nut. Do not tighten the lock nut yet. See Fig. 15
- For a 4 stage: align the top remaining hole on the Inboard black leg with the top hole on the gray leg. For a 6 stage & 8 stage: align the second hole from the bottom on the inboard black leg with the top hole on the gray leg. Place a 1/2" x 3" bolt through the holes and fully tighten this 1/2" nylon locknut. Repeat for the other two legs.
- If the holes do not align perfectly, some adjustments can be made on the slots on the Mounting Feet attached to the bin, and the Connecting Brackets under the Base Ring.
- 

Figure 15: Installing the Upper Inboard 44" Black Leg



## 6. INSTALL THE CROWN PLATE

### All models

Please refer to Figure 16-18 for the correct orientation of the crown plate segments in preparation for the assembly. Note the direction of the tab. In addition to this, the outside of the tab on side A is marked by a white dot.

Figure 16. The correct orientation of the segment:



Side A of one segment should always overlap on the outside the Side B of the adjoining segment

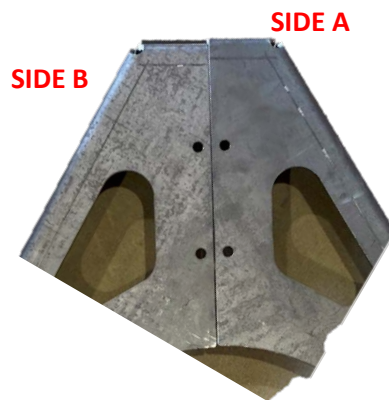


Figure 17. Assembled crown plate top side

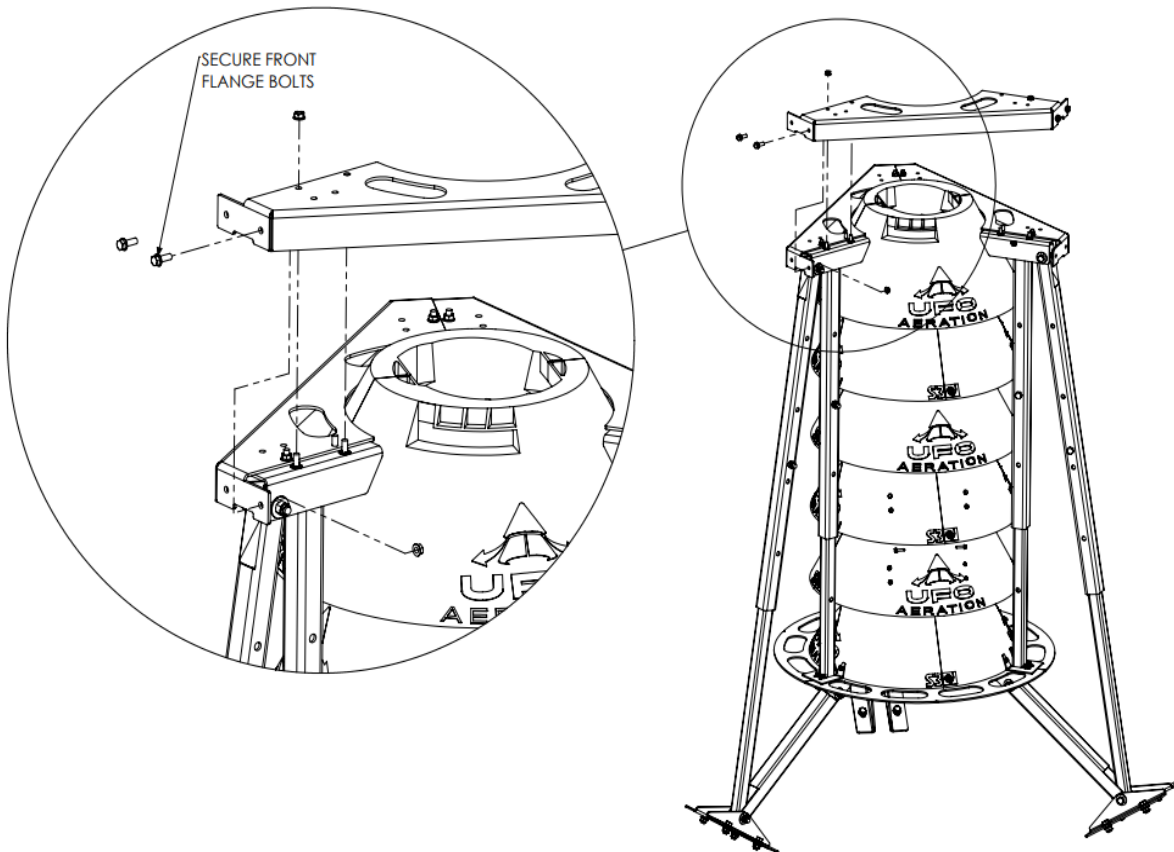


Figure 18 Assembled crown plate the reverse side

### 6A. 4-Stage and 6-Stage UFO's

- Install the crown plate parts one at a time. The bolts that stick out of the top leg bracket should align with the holes on the Upper Ring plates. Install 3/8" whiz nuts on the outside pairs of bolts (leave the inside bolts for now). Tighten the nuts to the appropriate torque value. See Figure 19A. Re-check the level of the unit.
- Install and secure the 6 front 3/8" x 1" flange bolts that connect the flanged segments together.

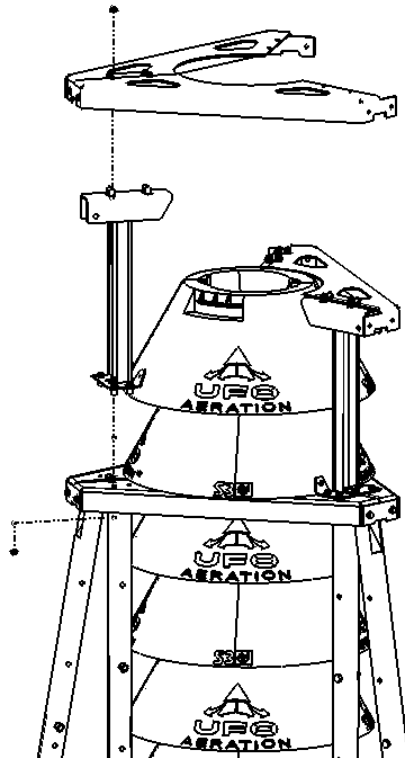
**Figure 19A: Installing the Crown plate**



**6B. V3 8 STAGE ADDITIONAL CONES AND TOP COLUMN LEGS**

- After installing the upper ring you will now add the two additional cones in the same manner as outlined in previous steps. After cone installation use hardware to install top column legs and shown in figure 19B.
- Once the bottom plate of the top column legs is secured attach the top crown plate in the same manner as step 6A.

Figure 19B – V3 8Stage Top 2 Stages, 3 Top Column Legs and Top Ring



## 7. INSTALL THE NOSE CONE (ALL MODELS)

You are going to need:

3 – Clamping Tabs

1 – Nose Cone

From the Bolt Kit:

6 – 3/8" whiz nuts

5 – Self-tapping 1/4" screws

- Ensure that none of the UFO Stages have rotated out of position by performing one last counter clockwise rotation of each of the stages from bottom to top.
- Place the Nose Cone on top of the top Stage and rotate it until it falls in. The lower circle of the Nose Cone should also be inset into the hole in the Upper Ring. Rotate it to lock it to the stage in the same manner as was done for the stages. The lip of the Cone should be about 1/4" above the top of the Upper Ring. See Figure 20A.
- Place the slots of the Clamping Tabs over the inner bolts that protrude out of the Upper Ring. Push the Clamping Tabs tight against the Nose Cone and tighten the 3/8" whiz nuts to the appropriate torque value. Fasten the screws through the holes in the Tab and into the Nose Cone.

Figure 20A: Installing the Nose Cone and Clamping Tabs

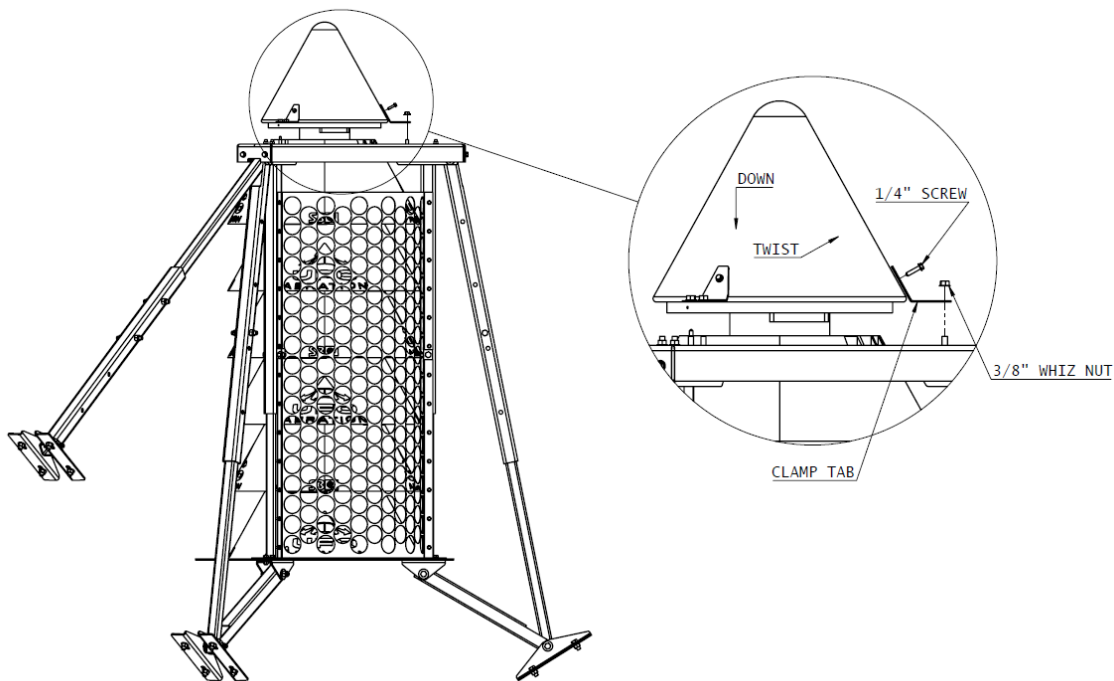
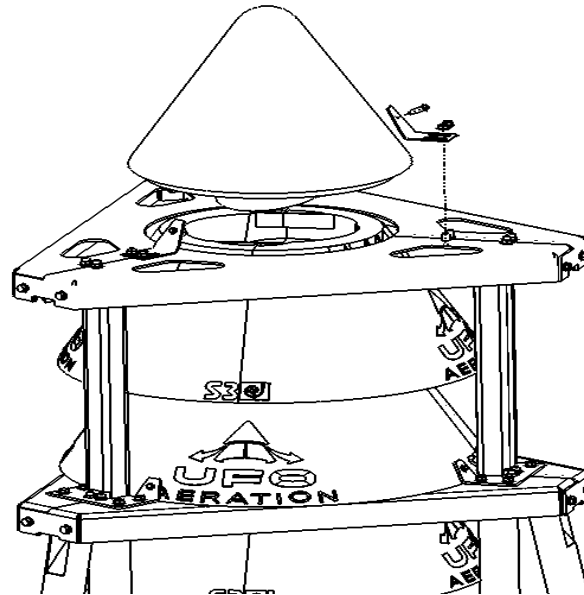


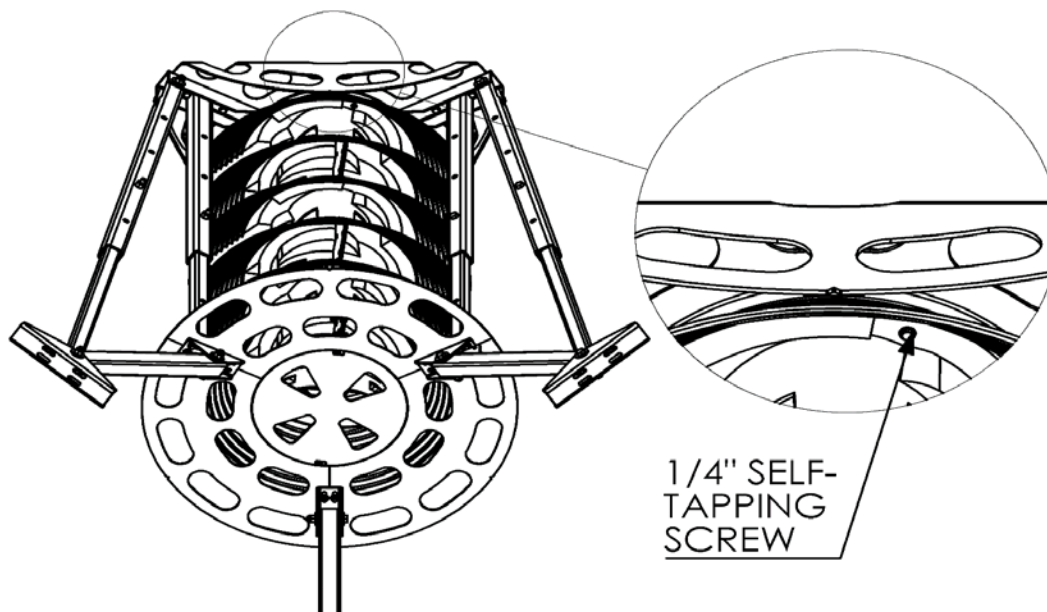


Figure 20B: Installing the Nose Cone and Clamping Tabs



**All Models:** Reaching into the bottom of the top Stage, fasten a screw through the top of that Stage in through the bottom of the Nose Cone to lock them together. Repeat this on the opposite side. See Figure 21.

Figure 21: Fasten the Top Stage to the Nose Cone





---

## 8. INSTALL THE OUTBOARD LEGS

You are going to need:

- 3 – Upper Outboard 1-1/2" (with Cap)
- 3 – Lower Outboard
- 6 – Double Foot - “L” shaped

From the Bolt Kit:

- 2 - 1/2" x 3-1/2" bolt
- 2 - 1/2" x 3" bolt
- 2 - 1/2" Nylock Nut
- 2 - 1/2" USS Washer

Refer to Figure 22.

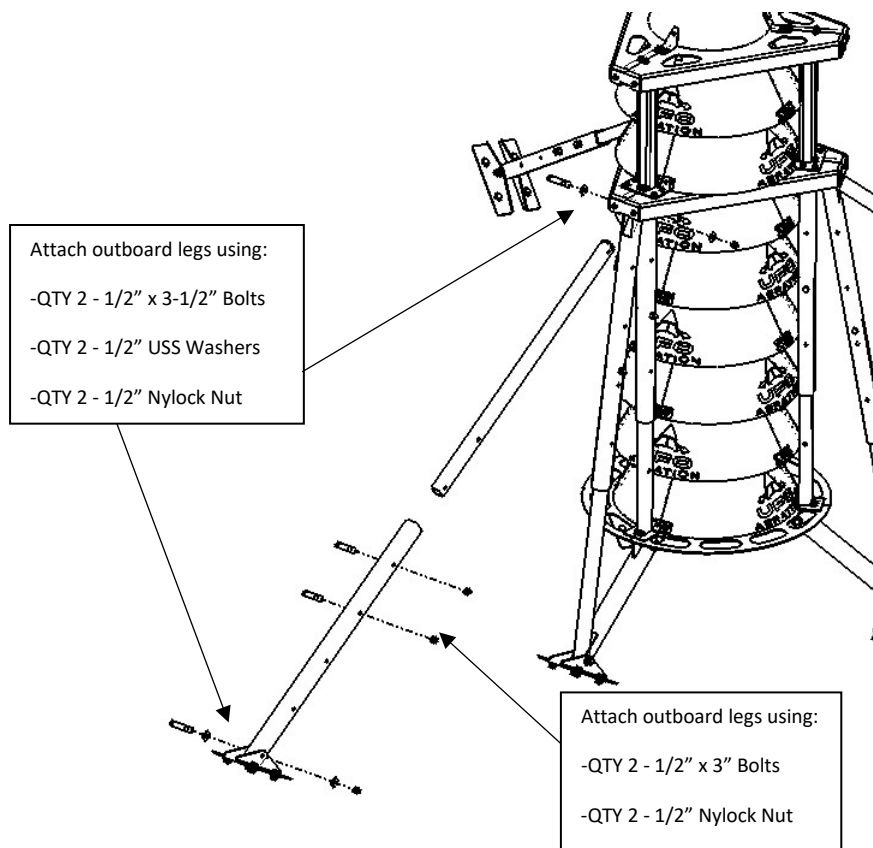
- Find your remaining 3 Upper Outboard Gray Legs, which have no washers welded to them. Carefully remove one 1/2" nut and washer from one of the brackets at the Crown plate. Pull the bolt almost fully out, and install the long leg by pushing the bolt through the bracket, Inboard Black Leg, and Outboard Gray Leg, all the way through to the other side. Use a punch to help align all the holes.
- Re-install the washer and nut, and this time tighten the nut to the specified torque value. Repeat for the other two legs.
- Get the remaining 3 Lower Outboard Black Legs. Slide the leg over the recently installed Outboard Gray Leg; make sure that the hole that is closest to the end is toward the bottom. For a 4 stage, align the 3rd hole from the top with the bottom hole on the Gray Leg. For a 6 stage & 8 stage, align the 2nd hole from the top with the bottom hole on the Gray Leg.
- Insert the 1/2" x 3" bolt as shown, and tighten on the nut. Repeat for the other two legs.
- Get the remaining 3 pairs of Double Feet. Install on the very end of the Black Leg using a 1/2" x 3-1/2" bolt, washers, and nylock nut. Tighten to torque value specified. Repeat for the other two feet.
- Let these Double Feet rest against the bin floor. Set them so that they are parallel with the legs on the same side.
- Mark the 4 holes per foot on the floor, in the centre of the slots. Shift the foot to the side to drill these holes. Fasten with the 3/8" whiz bolts and nuts as was done with the first 3 feet.

**Note:**

In the case that something was not done correctly in the steps above and the unit is not level, there is still a way to rectify it. First, there is some adjustment available in the slots of the “U”-shaped feet in the Lower Support Base, and in the Double Feet. These joints can be loosened and shifted to achieve a level unit.

If the unit is still not level and requires more adjustment, the extra holes in the black legs can be utilized for a custom fit. You will need to align the unit to level, and drill new 1/2” holes in the gray legs where they line up with spare holes in the black legs. Then install the 1/2” bolts and nuts through these newly aligned holes.

Figure 22: Installing the Outboard Black Legs



## 9. INSTALL THE DUCTING (ALL MODELS)

You are going to need:

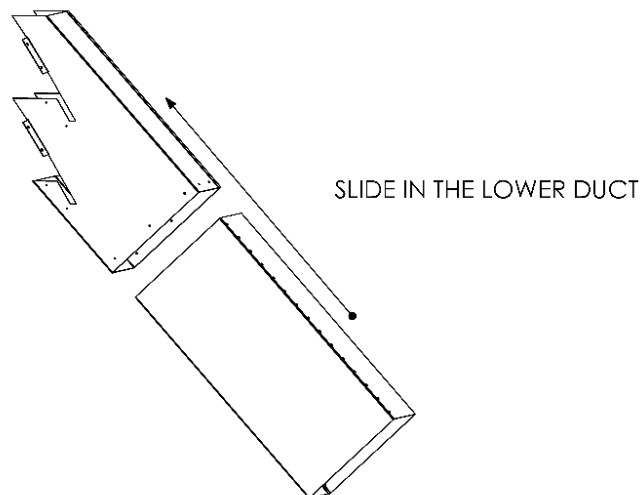
- 1 – Upper Duct (it looks like a weird, notched claw)
- 1 – Lower Duct
- 1 – Duct Elbow, with End Cap (leave this outside of the bin)
- 1 – Flange, made up of two 9" flange pieces and 14" flange pieces that will form a rectangle (leave this outside of the bin)
- 10' – Neoprene (leave outside of the bin)

From the Bolt Kit:

- 30 – Self-tapping ¼" screws
- 16 – 3/8" x 1-1/2" whiz bolts
- 16 – 3/8" whiz nuts

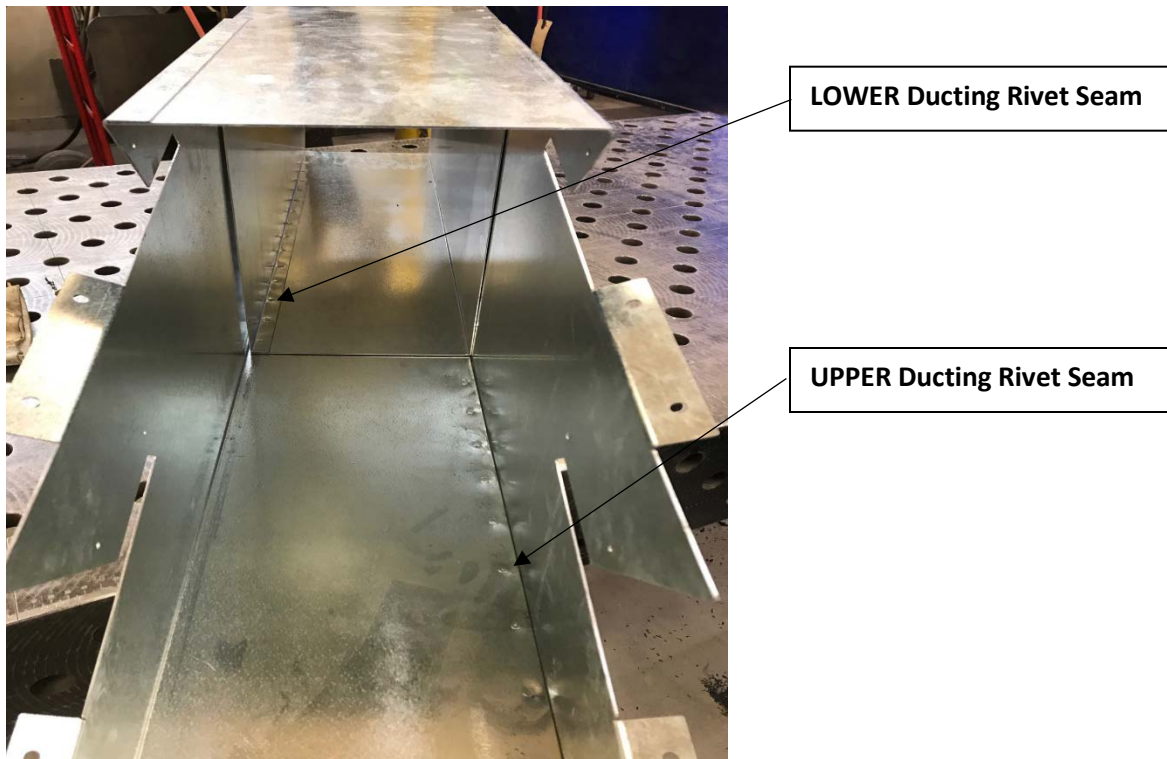
- Engage the Lower Duct into the Upper Duct, per Figure 23.

Figure 23:



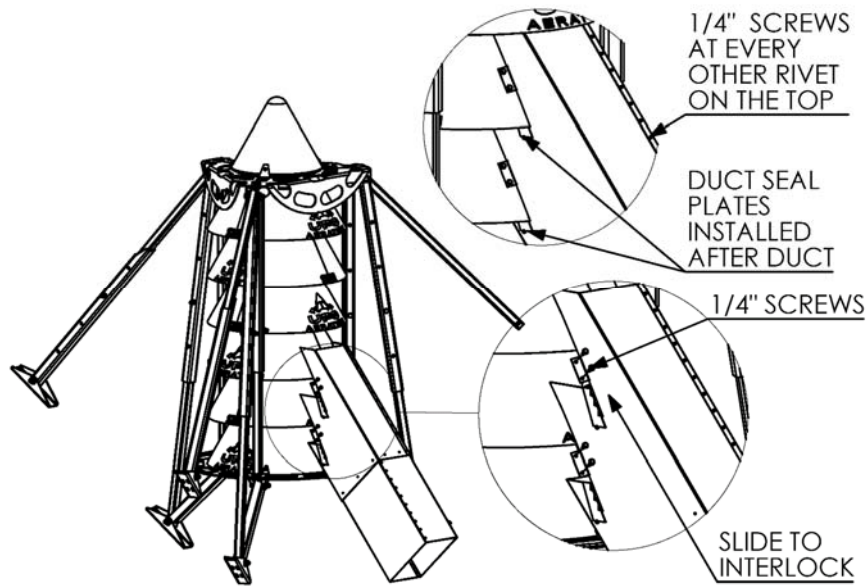
- When you open up your UFO kit, the Lower Duct should already be inserted into the Upper Duct. If it isn't or if you decided to take them apart, make sure that when you engage the Lower Duct into the Upper Duct the riveted seams are on opposite corners (as per Figure 24) to avoid unnecessary binding when sliding the two ducts within each other.

Figure 24: Duct Seams



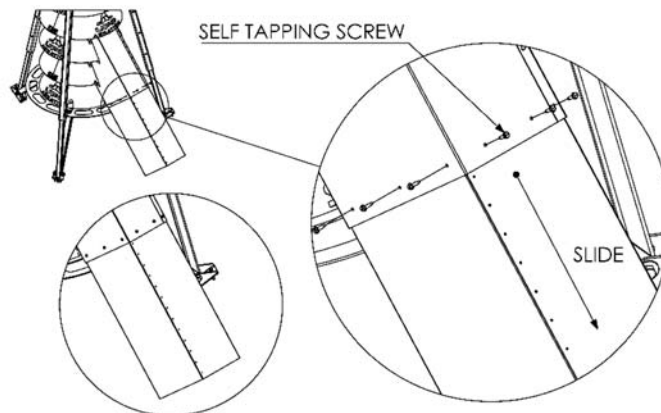
- Slide the two notches of the ducting into the bottom rims of the 2<sup>nd</sup> and 3<sup>rd</sup> UFO Stage, central to the V-notch in the Base Ring.
- Extend the Lower Duct out from the Upper Duct until it contacts the hopper cone.
- Using your marker, trace the perimeter of the ducting against the hopper wall.
- Move the Lower and Upper Ducting out of your way so you can drill holes in the 4 corners of the perimeter.
- From inside or outside the bin and using the 4 holes as a guide, use either a cutting torch or zip disc to cut the duct opening through the hopper. Have your fire extinguisher handy just in case.
- Reinstall the Lower and Upper Ducting into the bottom rims of the 2<sup>nd</sup> and 3<sup>rd</sup> UFO Stage, central to the V-notch on the Base Ring just like you did earlier.
- Using self-tapping screws, fasten the notched ducting to the UFO stage wall, per Figure 25.

Figure 25: Attaching the Duct to the Unit (ALL MODELS)



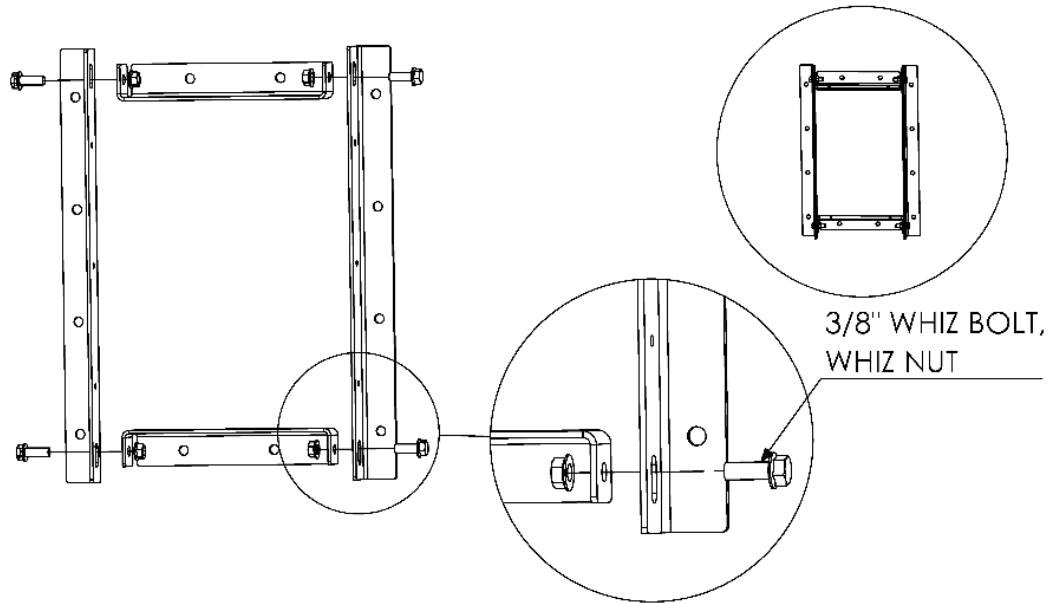
- Install the Duct Seal Plates (tied to Upper Duct) with ¼" Self-Tapping Screws.
- Extend the Lower Duct toward the opening you just cut in the hopper to ensure it fits properly up to or through the hole.
- Dry fit the Duct Elbow onto the Lower Duct to ensure proper length of lower duct and elbow fit accordingly. Once confirmed or adjusted accordingly, remove the Duct Elbow.
- From inside the bin, use self-tapping screws to fasten the Lower Duct to the Upper Duct, per Figure 26. From the top of the ducting, install ¼" Self-Tapping Screws in place of every other rivet along the length of the ducting (Figure 25).

Figure 26: Fastening the Ducts to Each Other



- Using the Duct Elbow as a guide, now assemble the Duct Flange to fit the Elbow properly, per Figure 27.

Figure 27: Assembling the Mounting Flange



- From outside the bin, hold the Flange up to the duct opening that has been cut in the hopper and mark out the 12 mounting holes for the Flange.
- Drill the holes in the hopper using the 7/16" drill bit.
- Install a neoprene seal around the perimeter of the Duct Flange.
- Bolt the Flange to the outside of the hopper using twelve 3/8" x 1-1/2 bolts and nuts. It is easier to drop bolts into the holes from the inside of the bin, let gravity hold them in place, and then secure them with nuts outside the bin.
- Mount the Duct Elbow into the Flange and use self-tapping screws to mount the Duct Elbow, Flange, and Lower Duct together.
- When you are ready to install your aeration fan, remove the End Cap and be sure to follow the installation manual provided with your aeration fan.

## 10. The installation of the support screen

You are going to need:

2 – UFO Perforated Support

From the Bolt Kit:

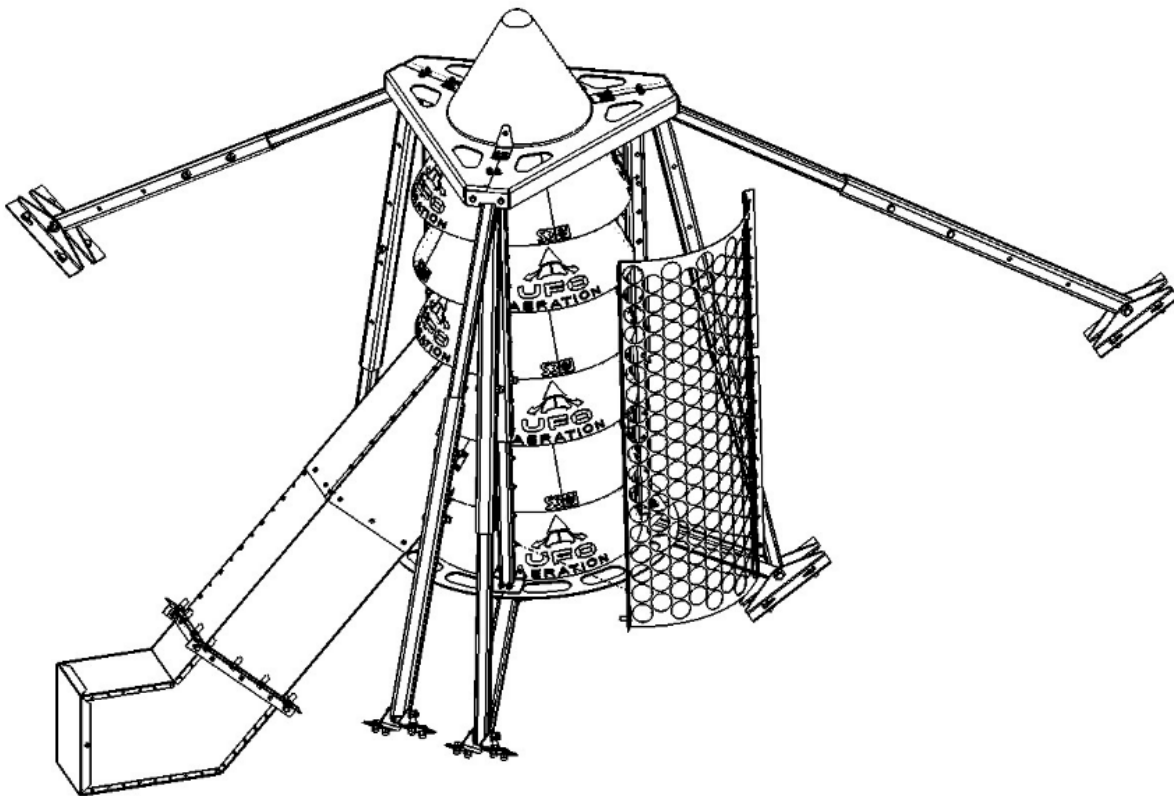
60 - 1/4"-14 UN x 1 Tek Screw

Place the screen in vertical position with the convex face facing you. Rest it on the lower support disc and place its bent flanges flush to the column legs. Using the existing holes in the mounting flanges, predrill into the column legs the holes for the TEK-screws you will install immediately thereafter. For this task, use a 3/16 drill bit. Repeat this for the second screen.

**IMPORTANT:** Each screen has to be mounted on the vertical columns, in the sections other than the one where the air duct is to be inserted.

Once the screens are fully mounted, please use the supplied plastic plugs and plug up the holes in the legs that are still expose; this will prevent grains and seeds from leaking into the leg tubes, thus causing premature corrosion.

Figure 28: The installation of the support screens in Stage 6 & 8

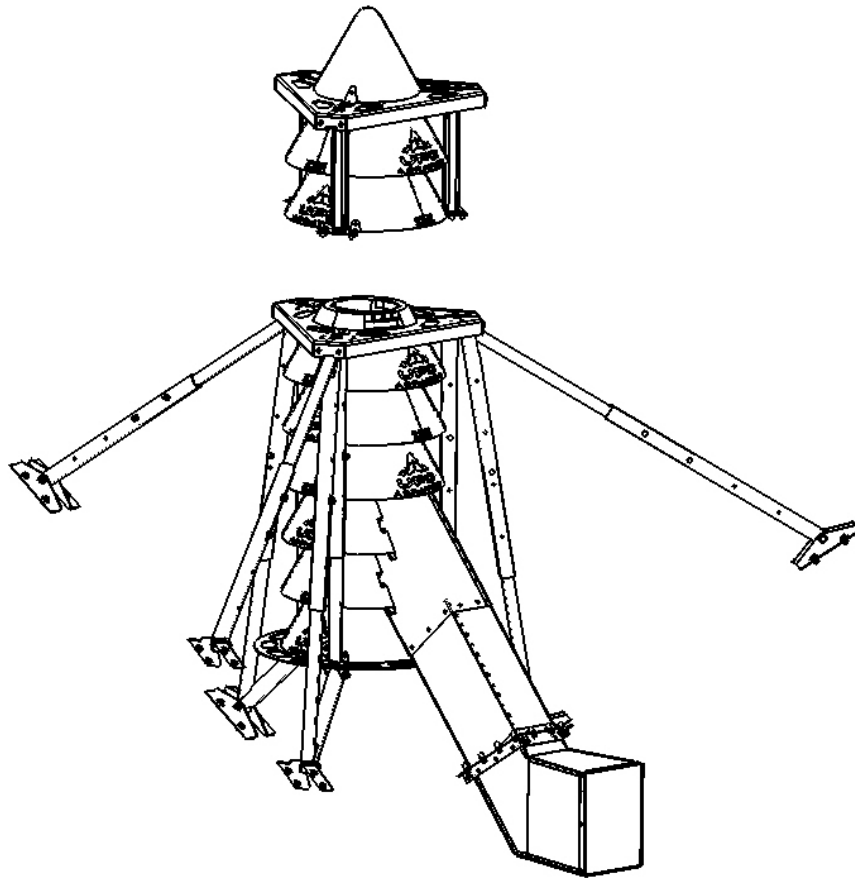




## 11. Transition Kit V3 6 Stage to V3 8 Stage

If you are the happy owner of a 6 stage UFO you can at any time upgrade to an 8 stage by purchasing an appropriate kit. In order to install the transition kit you will need to remove the upper ring, the cone, the brackets, and the two self-tapping screws depicted in figure 29.

Figure 29: Transition Kit V3 6 Stage to V3 8 Stage



Proceed then to the operation described in step 6b to install the upper ring, two additional stages, top ring, top column legs, and the associated hardware. The transition operation ends with the installation of the cone described in step 7.



## THE STUFF YOU MIGHT WANT TO REMEMBER

### **CONTACT INFORMATION:**

If you have any questions or need any help with your product call us at 306-773-0646 or toll free at 844-441-2020. The team at S3 is great and wants you to be happy with your purchase.

Videos and other information can be found on our website at [www.s3airsystems.com](http://www.s3airsystems.com) or on the S3 Enterprises YouTube channel.

### **CONGRATULATIONS YOU ARE NOW A UFO EXPERT!**

### **ADDENDUM:**

#### **Universal Hardware Parts Included in This Package**

31-117388	BOLT KIT- VERTICAL UNIVERSAL	
-----------	------------------------------	--

Revision 3		6/20/2023
PART NUMBER	PART DESCRIPTION	QTY
4001-22C2936	BOLT HEX 1/2 X 3" GR5	13
4001-22C2944	BOLT HEX 1/2 X 3-1/2" GR5	13
4024-22C0510	BOLT-FLG 1/2-13 UNC X 1 GR5	25
4024-22C2502	BOLT WHIZ 3/8 X 1" GR5	48
4024-22C2518	BOLT WHIZ 3/8 X 1-1/2" GR5	73
4046-13C0235	NUT WHIZ 3/8" GR5	126
4046-13C0500	NUT-HEX FLANGE 1/2-13 UNC GR5	25
4049-13C0260	NUT HEX NYLOCK 1/2" GR5	25
4890-50-8021	SCREW TEK 1/4-14 UN X 1"	95
5009-02-0500	WASHER FLAT USS 1/2"	148
NO NUMBER	SCREW TEK #10-16UN X 1-1/2"	2
		<b>593</b>

## Warranty & Limitations

### 1.0 WARRANTY

- 1.1** S3 AIR SYSTEMS Warranty Policy for all Aeration Products purchased from S3 AIR SYSTEMS is, all product shall be free from defects in workmanship and materials for a period of two (2) years from date of sale from S3 AIR SYSTEMS' dealer to the end user. To initiate the two (2) Year Warranty, the dealer must complete the Warranty Registration & Inspection Form on date of sale, and submit to S3 Air Systems.
- 1.2** The Warranty described herein is provided by S3 AIR SYSTEMS to the original purchaser of the Product. The Warranty is non-transferable.
- 1.3** S3 AIR SYSTEMS, at its option, will repair or replace any part covered by the Warranty in Section 1.1 during the Warranty Period on the following conditions:
- (a) Customer shall notify S3 AIR SYSTEMS of the defect within thirty (30) days of failure;
  - (b) Customer shall provide the respective Product's Serial Number.
  - (c) S3 AIR SYSTEMS, in its sole discretion, may contract out any repairs to the Customer or repair agent of its choice.
- 1.4** Eligible warranty repairs or replacement shall be free of charge to the original purchaser for materials, labor and shipping in the Warranty Period.
- 1.5** S3 AIR SYSTEMS shall be responsible for the repair or replacement of:
- (a) Defective parts or subassemblies incorporated in the Product that are warranted under original manufacturing warranties from OEM or third party suppliers;

### 2.0 NOT COVERED BY WARRANTY

- 2.1** S3 AIR SYSTEMS shall not be responsible for the repair or replacement of:
- (a) Products that have been altered or modified in any manner not approved or authorized by S3 AIR SYSTEMS; or
  - (b) Damage caused by normal wear and tear, lack of reasonable proper maintenance, misuse, excessive use, or damage caused by accident, vandalism or Act of God.

### 3.0 PURCHASER RESPONSIBILITIES

- 3.1** In order to establish eligibility for the Warranty set out herein, the Customer shall;
- (a) Notify S3 AIR SYSTEMS of the defect within thirty (30) days of date of failure and
  - (b) Provide S3 AIR SYSTEMS with the Product's Serial Number.
  - (c) Submit Warranty Registration & Inspection Form to S3 Air Systems at date of sale from dealer to end user.
- 3.2** Where Customer is authorized by S3 AIR SYSTEMS to make the repairs, the Customer's account shall be credited for the cost of the repairs, provided:
- (a) Customer provides S3 AIR SYSTEMS a detailed scope of work, labor hours required to complete the work, hourly rate and material costs ("Work");
  - (b) S3 AIR SYSTEMS approves the Work based on the details provided in para. (a);
  - (c) The warranty repairs and services are completed in a good and workmanlike manner according to prevailing industry standards;

- (d) The repairs are made in accordance with labor rates and price lists approved by S3 AIR SYSTEMS, or as prescribed by local provincial or State laws;
- (e) Customer obtains the prior approval of S3 AIR SYSTEMS if field diagnostic inspection is required. Travel and expenses must be pre-approved.

### 4.0 S3 AIR SYSTEMS RESPONSIBILITIES

- 4.1** S3 AIR SYSTEMS shall reply to the Customer's warranty notice in paragraph 3.1(a) within two (2) days of notification.
- 4.2** Upon receipt of the Products Serial Number set out in para. 3.1(b), S3 AIR SYSTEMS will evaluate the warranty claim and will provide a replacement under the Warranty upon completion of its evaluation.
- 4.3** S3 AIR SYSTEMS will require the return of the Product to S3 AIR SYSTEMS, the Customer or as S3 AIR SYSTEMS may choose by issuing an RMA, or may elect to credit Customer's account for the Customer's cost of the Product.
- 4.4** S3 AIR SYSTEMS will credit all shipping costs on all approved warranty repairs provided Customer complies with the shipping and related instructions in the RMA.

### 5.0 WARRANTY & LIABILITY LIMITATIONS

- 5.1** The Warranty provisions herein constitute the full extent of the warranties supplied by S3 AIR SYSTEMS for the Product.
- 5.2** S3 AIR SYSTEMS reserves the absolute and unconditional right to deny or reverse its approval of any Warranty claim in the case of fraud, abuse or error.
- 5.3** WITHOUT LIMITING THE GENERALITY OF THE FOREGOING AND TO THE EXTENT PERMITTED BY LAW, S3 AIR SYSTEMS HEREBY EXPRESSLY DISCLAIMS AND EXCLUDES ALL WARRANTIES AND CONDITIONS OF MERCHANTABILITY AND FITNESS FOR A PARTICULAR PURPOSE, WHETHER EXPRESS OR IMPLIED, STATUTORY OR OTHERWISE
- 5.4** Where the exclusion of implied or statutory warranties or conditions is prohibited by law, any such warranties or conditions shall be limited in duration to the warranty period set out herein..
- 5.5** **SUBJECT TO ANY STATUTORY EXCEPTIONS OR LIABILITY IMPOSED BY LAW, S3 AIR SYSTEMS'S LIABILITY FOR ANY CAUSE WHATSOEVER (INCLUDING NEGLIGENCE) IS HERBY LIMITED TO ACTUAL DAMAGES IN SUCH AN AMOUNT AS NOT TO EXCEED THE PURCHASE PRICE OF THE PRODUCT GIVING RISE TO THE WARRANTY CLAIM.**
- 5.6** **IN NO EVENT SHALL S3 AIR SYSTEMS BE LIABLE FOR ANY INCIDENTAL, INDIRECT, SPECIAL OR CONSEQUENTIAL DAMAGES, EVEN IF ADVISED OF THE POSSIBILITY THEREOF, INCLUDING DAMAGES FOR LOSS OF USE OF THE PRODUCT, OR LOSS OF BUSINESS OR PROFITS AS A RESULT.**

### 6.0 GENERAL

- 6.1** This Warranty shall be governed by and subject to the *Terms & Conditions of Sale* of the Product, including without limitation "Limited Warranty" and "Governing Law" provisions thereof.
- 6.2** For greater clarity, and subject to any local laws or statutes to the contrary, the provisions of this Warranty shall be governed by the laws of the Province of Saskatchewan, and shall be subject to the exclusive jurisdiction of the courts therein.





Innovation • Precision • Sustainability



**S3 Group Ltd.**  
2180 Oman Drive  
P.O. Box 39  
Swift Current, SK S9H 3V5  
Canada

Phone: 306-773-0644  
Fax: 306-773-1188



**S3 Delta Harrows**  
800 S. Fremont Street  
Shenandoah IA 51601  
USA

Toll Free: 877-874-3020  
Phone: 712-246-3020  
Fax: 712-246-3022



**S3 Wireform**  
2180 Oman Drive  
P.O. Box 1207  
Swift Current SK S9H 3X4  
Canada

Toll Free: 844-441-1010  
Phone: 306-773-0644  
Fax: 306-773-1188



**S3 Air Systems**  
2180 Oman Drive  
P.O. Box 696  
Swift Current SK S9H 3W7  
Canada

Toll Free: 844-441-2020  
Phone: 306-773-0646  
Fax: 306-773-9318



**S3 Manufacturing**  
2180 Oman Drive  
P.O. Box 1780  
Swift Current SK S9H 4J8  
Canada

Toll Free: 844-441-3030  
Phone: 306-773-0646  
Fax: 306-773-9318

Industrial product development solutions.

[S3grouppltd.com](http://S3grouppltd.com)